

U
N
I
Q
U
E



CATALOGO

Unique

by SCRIGNO®

DISEGNA LA TUA CASA

NUOVE PORTE UNIQUE. MODERNITA' ED ESSENZIALITA' DISEGNANO LA TUA CASA

Unique è il marchio che contraddistingue le porte prodotte da Scigno, leader nei sistemi per porte e finestre scorrevoli. Nelle case di oggi e di domani, le persone chiedono alle porte di interpretare il loro stile abitativo. Con Unique il design prende spazio e trasmette emozione. La porta diventa un'elegante ed imprescindibile componente dell'arredo, carica di valori emozionali, di comunicazione, di status e di ricercatezza. Esaltazione della qualità dei materiali, strutture volutamente ridotte, volumi nitidi ed essenziali, ampie possibilità di personalizzazione, sono all'origine delle porte Unique, disponibili in colori neutri capaci di adattarsi a diversi contesti di arredo, creando per le finiture interne un appeal caldo, confortevole e di effetto sorprendente.



Unique Flyer battente, vetro Cannes orizzontale e nero lucido / swinging door, horizontal Cannes and black glass / avec battant verre Cannes horizontal et noir brillant / Drehflügeltür, horizontal strukturiertes Cannes-Glas und schwarz Glanzglas / battant cristal Cannes horizontal y negro brillante

NEW UNIQUE DOORS. MODERNITY AND ESSENTIALITY DESIGN YOUR HOME.

Unique is the brand name that is the hallmark of doors produced by Scigno, a world leader in sliding door and window systems. In the houses of today and tomorrow, people want doors that interpret their living style. Thanks to Unique, design takes space and transmits emotions. Doors become elegant and essential furnishing elements, transmitting emotions, communication, status and sophistication. The use of quality materials, intentionally smaller structures, clean and essential volumes and a wide range of customizations are the key to Unique doors, available in neutral colours capable of flexibly adapting to a variety of furnishing contexts, creating a warm, comfortable and surprising appeal for interiors.

LES NOUVELLES PORTES «UNIQUE». MODERNITÉ ET ESSENTIALITÉ DESSINENT VOTRE MAISON.

«**Unique**» est la marque qui distingue les portes produites par Scigno, leader des systèmes pour portes et fenêtres coulissantes. Dans les maisons d'aujourd'hui et de demain, les personnes demandent aux portes d'interpréter leur style d'intérieur. Grâce à «Unique», le design gagne de l'espace et transmet une émotion. La porte devient un élément élégant et indispensable du mobilier, riche en valeurs émotionnelles, de communication, de statut et de raffinement. L'exaltation de la qualité des matériaux, les structures délibérément réduites, les volumes nets et essentiels ainsi que de nombreuses possibilités de personnalisation sont les caractéristiques de base des portes «Unique», celles-ci étant disponibles dans des teintes neutres, en mesure de s'adapter souplement à des contextes d'ameublement variés, créant (pour les finitions intérieures) un appeal chaud, confortable et d'un effet surprenant.



Unique Flyer scorrevole anta doppia vetro Tree nero / double sliding door, black Tree glass / coulissant vantail double, verre Tree noir / Doppelflügel-Schiebetür, Tree schwarz Ätztglas / corredera de dos hojas, cristal Tree negro

NEUE TÜREN UNIQUE. MODERNE UND ESSENZIELLE FORMEN GESTALTEN IHR ZUHAUSE.

Unique ist die Marke, die den Unterschied für die Türen aus dem Hause Scrigno, dem führenden Hersteller von Systemen für Schiebetüren und -fenster, ausmacht. In den Wohnungen von heute und morgen erwartet man, dass die Türen den ausgewählten Wohnstil interpretieren. Mit Unique nimmt das Design Formen an und weckt Gefühle. Die Tür wird zu einer eleganten und unverzichtbaren Komponente der Einrichtung, die Emotionen ausstrahlt und Kommunikation, Status und Raffiniertheit bietet. Spitzenqualität der Materialien, absichtlich verkleinerte Strukturen, reine und essenzielle Konturen, weit reichende Möglichkeiten der Personalisierung sind die Grundlagen der Türen Unique, die in neutralen Farben angeboten werden, sich somit geschmeidig unterschiedlichen Einrichtungskontexten anpassen und den internen Finishes einen warmen, komfortablen und überraschenden Appeal verleihen.

NUEVAS PUERTAS UNIQUE. LA MODERNIDAD Y LA SOBRIEDAD DISTINGUEN TU HOGAR.

Unique es la marca distintiva de las puertas fabricadas por Scrigno, líder de los sistemas para puertas y ventanas correderas. En los hogares de hoy y del mañana, las personas requieren que las puertas interpreten su estilo de vivienda. Con Unique el diseño se abre camino y transmite emoción. La puerta se convierte en un elegante e imprescindible componente de la decoración, lleno de valores emocionales, de comunicación, de status y sofisticación. La notable calidad de los materiales, las estructuras reducidas ex profeso, los volúmenes netos y austeros, así como las amplias posibilidades de personalización caracterizan a las puertas Unique, disponibles en colores neutros capaces de adaptarse dúctilmente a varios contextos decorativos, creando en los acabados interiores un atractivo cálido, confortable y de efecto sorprendente.

DISTINTIVITÀ, ESCLUSIVITÀ, RICERCATEZZA

Queste sensazioni sono il cuore delle nuove porte Unique, dove classe ed eleganza si confermano e si rinnovano. La caratterizzazione è marcata, proprio per sottolineare l'appartenenza al mondo di una grande marca. Le linee essenziali liberano la fantasia, mentre disegnano lo spazio. Lo stile si esprime nelle forme, nelle texture, nell'armonia. Materiali opachi e trame trasparenti si combinano, creano simmetrie, reinventano la luce. Scopriamo un richiamo emotivo al passato, con le linee rigorose e geometriche, con la presenza di un traverso superiore sporgente sullo stipite rispetto ai montanti, come le porte erano concepite un tempo. Così, la nuova gamma interpreta i trend del design per interni: maniacalità degli accoppiamenti, cura dei dettagli e delle finiture, modularità tra vetri differenti che creano particolari effetti di luce, essenze e colori più ricercati, accostandosi al mondo dell'arredo come prodotti di classe ed esclusivi.



Unique Mind scorrevole anta singola per Essential vetro Extra Clear / single sliding door for Essential, Extra-Clear glass / coulissant vantail simple pour Essential verre Extra Clear / Einzelflügel-Schiebetür für Essential, Extra-Clear-Glas / corredera de una hoja para Essential cristal Extra Clear

DISTINCTION, EXCLUSIVITY, SOPHISTICATION

These sensations are at the heart of new Unique doors, which reconfirm and renew a sensation of class and elegance. The marked characterization aims to underline the fact they are part of a great brand. The essential lines free the imagination and design space. Style is expressed through shapes, textures and harmony. Opaque materials and transparent textures combine to create symmetries and reinvent light. We discover an emotional reminder of the past, with rigorous and geometric lines, the presence of an upper cross-piece jutting out over the door posts compared to the jambs, just as doors were designed once upon a time. The new range interprets the design trend for interiors - obsessive combinations, attention to detail and finishes, modularity in the use of various types of glass to create particular light effects and more sophisticated woods and colours make them an exclusive and sophisticated product in the world of furnishing.

DISTINCTION, EXCLUSIVITÉ, RAFFINEMENT

Ces sensations sont le cœur des nouvelles portes «Unique», l'expression d'une classe et d'une élégance qui s'affirment et se renouvellent. La caractérisation est intentionnellement marquée pour souligner l'appartenance au monde d'une grande marque. Les lignes essentielles libèrent la fantaisie tout en dessinant l'espace. Le style s'exprime dans les formes, dans les textures et dans l'harmonie. Les matériaux opaques et les trames transparentes se fondent, créant des symétries et réinventant la lumière. Elles suggèrent un rappel troublant du passé, évoqué dans les lignes géométriques rigoureuses et dans la présence d'une traverse supérieure en saillie par rapport aux montants, à l'instar des portes d'autrefois. Cette nouvelle gamme, qui interprète les trends du design d'intérieur privilégiant la perfection des accouplements, le soin des détails et des finitions, la modularité entre verres différents pour de surprenants effets de lumière ainsi que les essences et les teintes les plus raffinées, s'intègre au monde du mobilier comme un produit de classe des plus exclusif.



Unique Lorica anta doppia, vetro reflecting bronze e essenza Ebano / double door, Reflecting Bronze glass and Ebony / coulissant vantail double, verre Bronze Foncé et Ebène / Doppelflügel, Bronzefarbenes Reflecting-Glas und Ebenholz / de dos hojas, cristal Bronze Reflecting y Ebano

DISTINGUIERTHEIT, EXKLUSIVITÄT, RAFFINIERTHEIT

Diese Empfindungen sind der Kern der neuen Türen Unique, in denen Klasse und Eleganz sich bestätigen und erneuern. Die Charakterisierung ist bewusst gekennzeichnet, um die Zugehörigkeit zur Welt einer großen Marke zu unterstreichen. Die essenziellen Linien geben der Phantasie freien Lauf und verleihen dem Raum Gestalt. Der Stil findet seinen Ausdruck in den Formen, in der Textur, in der Harmonie. Lichtundurchlässige Materialien und durchsichtige Einschüsse kombinieren sich, kreieren Symmetrien, lassen das Licht neu wirken. Man wird emotionell an die Vergangenheit erinnert – dank der strengen, geometrischen Linien und der an der Zarge überstehenden oberen Querschiene oberhalb der Ständer, so wie sie einst für die Türen konzipiert wurden. Auf diese Weise interpretiert die neue Serie die Design-Trends für Innenbereiche: gezielte Wiederholung der Paarungen, sorgfältige Auswahl der Details und Finishes und gestaffeltes Angebot verschiedener Verglasungen, um besondere Lichteffekte herzustellen, ausgesuchte Essenzen und Farben anzubieten, hochklassige und exklusive Produkte in die Inneneinrichtung einfließen zu lassen.

DISTINCIÓN, EXCLUSIVIDAD, SOFISTICACIÓN

Estas sensaciones son el corazón de las nuevas puertas Unique, donde clase y elegancia se reafirman y se renuevan. Un carácter muy marcado, justamente para poner de relieve la pertenencia al mundo de una gran marca. Las líneas esenciales dan rienda suelta a la fantasía al trazar los espacios. El estilo se expresa en las formas, en las texturas, en la armonía. Materiales opacos y tramas transparentes se combinan, crean simetrías, reinventan la luz. Descubrimos un regreso emotivo al pasado, con líneas rigurosas y geométricas o con la presencia de un travesaño superior encima de la jamba que sobresale con respecto a los montantes, siguiendo la antigua concepción de las puertas. Así, la nueva gama interpreta las tendencias del diseño de interiores - en la obsesión por crear combinaciones, en el cuidado de los detalles y los acabados, en la modularidad entre cristales distintos que generan efectos de luz singulares, en los materiales y colores más sofisticados - vinculándose al universo de la decoración como línea de productos de clase, exclusivos.

LA NUOVA GAMMA UNIQUE SI ARTICOLA IN TRE LINEE: FLYER, MIND E LORICA

THE NEW UNIQUE RANGE HAS THREE LINES: FLYER, MIND AND LORICA

LA NOUVELLE GAMME «UNIQUE» SE DÉCLINE EN TROIS LIGNES: FLYER, MIND ET LORICA

DIE NEUE SERIE UNIQUE IST IN FOLGENDE DREI LINIEN UNTERTEILT: FLYER, MIND UND LORICA

LA NUEVA GAMA UNIQUE SE ARTICULA EN TRES LÍNEAS: FLYER, MIND E LORICA

UNIQUE Q N D



UNIQUE FLYER

Estetica innovativa, minimalismo assoluto dei profili ridottissimi degli stipiti piatti che esaltano ogni scelta di colore e di materiali.

Innovative aesthetics, absolute minimalism in the shorter profiles of the flat door posts that exalt every colour and material choice.



Unique Flyer scorrevole anta doppia su Essential, vetro Tree nero / double sliding door for Essential, black Tree glass / coulissant vantail double pour Essential, verre Tree noir / Doppel-flügel-Schiebetür für Essential, Tree schwarz-Glas / corredera de dos hojas, para Essential, cristal Tree negro

Esthétique innovante, minimalisme absolu des profils réduits des montants plats qui exaltent toute possibilité de choix dans les teintes et dans les matériaux.

Innovative Ästhetik, absoluter Minimalismus der nahezu unscheinbaren Profile flach gehaltener Zargen, die jede Farb- und Materialauswahl unterstützen.

Estética innovadora, minimalismo absoluto de los perfiles reducidos de las jambas planas que dan realce a todo tipo de colores y materiales.



Unique Flyer scorrevole anta singola, Zebrano / single sliding door, Zebrawood / coulissant vantail simple, Zebrano / Einzelflügel-Schiebetür Zebrano / corredera de una hoja, Zebrano



Unique Flyer scorrevole e battente anta singola Essential Ebano / single sliding and swinging door Essential, Ebony / coulissant vantail et battant simple Essential, Ebène / Einzelflügel-Schiebetür und Drehflügeltür Essential Ebenholz / corredera y batiente de una hoja Essential, Ébano

**LE VERSIONI
DISPONIBILI SONO:**

SCORREVOLE INTERNO MURO,
singolo e doppio
SCORREVOLE ESTERNO MURO,
singolo e doppio
BATTENTE singolo

THE VERSIONS AVAILABLE ARE:

INTERNAL SLIDING DOOR SYSTEM,
single or double panel
EXTERNAL SLIDING DOOR SYSTEM,
single or double panel
Single DOOR PANEL



Unique Flyer battente, vetro Cannes orizzontale e nero lucido / swinging door, horizontal Cannes and black glass / avec battant verre Cannes horizontal et noir brillant / Drehflügeltür, horizontal strukturiertes Cannes-Glas und schwarz Glanzglas / batiente cristal Cannes horizontal y negro brillante

DISPONIBLE DANS LES VERSIONS:

COULISSANT À L'INTÉRIEUR DE LA CLOISON,
simple et double
COULISSANT À L'EXTÉRIEUR DE LA CLOISON,
simple et double
VANTAIL simple

VERFÜGBARE VERSIONEN:

SCHIEBETÜR AN WANDINNENSEITE,
einfach und doppelt
SCHIEBETÜR AN WANDAUSSENSEITE,
einfach und doppelt
EINZELFLÜGEL

LAS VERSIONES DISPONIBLES SON:

PUERTA CORREDERA EMPOTRADA EN LA PARED, de una y de dos hojas
PUERTA CORREDERA POR FUERA DE LA PARED, de una y de dos hojas
PUERTA BATIENTE de una hoja.



UNIQUE FLYER

Unique Flyer scorrevole anta doppia, vetro bronze acidato e marrone lucido

Unique Flyer, double sliding door, etched bronze glass and glass brown



Unique Flyer coulissant vantail double, verre bronze acide et marron brillant

Unique Flyer Doppelflügel-Schiebetür, bronzefarbenes Ätzglas und braunes Glanzglas

Unique Flyer corredera de dos hojas, cristal bronce translúcido y marrón brillante



UNIQUE FLYER

Unique Flyer scorrevole esterno muro,
vetro bronze acidato e marrone lucido

Unique Flyer, external sliding door,
etched bronze glass and gloss
brown

Unique Flyer coulissant en
extérieur mur simple, verre
bronze acide et marron brillant

Unique Flyer Einzelschiebetür für
Außenwand, bronzefarbenes Ätz-
glas und braunes Glanzglas

Unique Flyer corredera paralela a
la pared, cristal bronze translúcido
y marrón brillante



UNIQUE FLYER

Unique Flyer battente Essential e Flyer battente, vetro Cannes orizzontale e grigio lucido

Unique Flyer, swinging Essential and swinging door, horizontal Cannes glass and light grey

Unique Flyer avec battant Essential et battant verre Cannes horizontal et gris brillant

Unique Flyer Drehflügeltür Essential und Drehflügeltür, horizontal strukturiertes Cannes-Glas und graues Glanzglas

Unique Flyer batiente Essential y batiente cristal Cannes horizontal y gris brillante

UNIQUE MIND



UNIQUE MIND

Esaltazione della modernità e dell'essenzialità. Strutture ridotte, stipiti piatti, volumi nitidi, risalto del vetro quale materiale dominante per dare luminosità ed armonia alla casa.

The exaltation of modernity and essentiality. Smaller structures, flat door posts, clean volumes and the use of glass as the dominating material give light and harmony to the home.



Unique Mind scorrevole anta doppia su Essential vetro Extra Clear acidato / double sliding door for Essential etched Extra-Clear glass / coulissant vantail double pour Essential verre Extra Clear acide / Doppelflügel-Schiebetür für Essential, bronzefarbenes Extra-Clear-Glas / corredera hoja doble para Essential cristal Extra Clear translúcido

Exaltation de la modernité et de l'essentialité. Structures réduites, montants plats, volumes nets, affirmation du verre comme matériau dominant à même d'assurer luminosité et harmonie à l'intérieur.

Maximaler Ausdruck der Modernität und der Schlichtheit. Verkleinerte Strukturen, flache Zargen, reine Konturen, Glas als dominierendes Material, um dem eigenen Heim Licht und Harmonie zu verleihen.

Exaltación de la modernidad y la sobriedad. Estructuras reducidas, marcos planos, volúmenes nítidos, realce del cristal como material dominante para dar luminosidad y armonía a la casa.



UNIQUE MIND

Unique Mind scorrevole anta doppia vetro Extra Clear acidato

Unique Mind, double sliding door, etched Extra-Clear glass

Unique Mind Doppelflügel-Schiebetür, Extra-Clear-Glas

Unique Mind coulissant vantail double verre Extra Clear acide

Unique Mind corredera hoja doble cristal Extra Clear translúcido



UNIQUE MIND

Unique Mind scorrevole esterno muro vetro Cannes orizzontale

Unique Mind, external sliding door, horizontal Cannes glass

Unique Mind Schiebetür für Außenwand, horizontal strukturiertes Cannes-Glas

Unique Mind coulissant en extérieur mur simple, verre Cannes horizontal

Unique Mind corredera paralela a la Pared cristal Cannes horizontal



UNIQUE MIND

Unique Mind scorrevole anta singola vetro
Extra Clear

Unique Mind, single sliding door,
Extra-Clear glass

Unique Mind coulissant vantail simple
verre Extra Clear

Unique Mind Einzelflügel-Schiebetür, Extra-
Clear-Glas

Unique Mind corredera de una hoja cristal Extra
Clear



Unique Mind battente vetro Cannes orizzontale / swinging door, horizontal Cannes glass / avec battant verre cannes horizontal / Drehflügeltür, horizontal strukturiertes Cannes-Glas / batiente cristal Cannes horizontal

LE VERSIONI DISPONIBILI SONO:
SCORREVOLE INTERNO MURO, singolo e doppio
SCORREVOLE ESTERNO MURO, singolo e doppio
BATTENTE singolo

THE VERSIONS AVAILABLE ARE:
INTERNAL SLIDING DOOR SYSTEM, single or double panel
EXTERNAL SLIDING DOOR SYSTEM, single or double panel
Single DOOR PANEL



DISPONIBLE DANS LES VERSIONS:

COULISSANT À L'INTÉRIEUR DE LA CLOISON,
simple et double
COULISSANT À L'EXTÉRIEUR DE LA CLOISON,
simple et double
VANTAIL simple

VERFÜGBARE VERSIONEN:

SCHIEBETÜR AN WANDINNENSEITE,
einfach und doppelt
SCHIEBETÜR AN WANDAUSSENSEITE,
einfach und doppelt
EINZELFLÜGEL

LAS VERSIONES DISPONIBLES SON:

PUERTA CORREDERA EMPOTRADA EN LA
PARED, de una y de dos hojas
PUERTA CORREDERA POR FUERA DE LA
PARED, de una y de dos hojas
PUERTA BATIENTE de una hoja.



UNIQUE MIND

Unique Mind scorrevole esterno muro
vetro bronze reflecting

Unique Mind, external sliding door,
bronze reflecting glass

Unique Mind coulissant en extérieur
de cloison, verre bronze reflecting

Unique Mind Schiebetür für
Außenwand, bronzefarbenes
Reflecting-Glas

Unique Mind corredera por
fuera de la pared cristal bronze
reflecting



UNIQUE MIND

Unique Mind scorrevole anta singola
per Essential vetro Extra Clear

Unique Mind, single sliding door,
for Essential Extra-Clear glass

Unique Mind coulissant vantail
simple pour Essential verre Extra
Clear

Unique Mind Einzelflügel-Schie-
betür für Essential, Extra-Clear-
Glas

Unique Mind corredera de una
hoja para Essential cristal Extra
Clear

UNIQUE



UNIQUE LORICA

Peculiarità del movimento dei pannelli porta "telescopico". Come un'antenna, parte del pannello porta scorre dentro l'altra ed insieme nel controtelaio, in una spalla di muro pari alla metà della luce di passaggio. Un'applicazione particolarissima, funzionale e di forte effetto spettacolare grazie alla varietà dei materiali abbinabili.

The "telescopic" panel door affords it its peculiar movement. Like an antenna, part of the door panel slides into the other and together they slide into the framing system in a wall abutment equal to half the clear opening space. A very unusual application that is functional and spectacular, thanks also to the variety of material combinations available.



Unique Loric anta doppia Bronze Reflecting ed essenza Ebano / double door, Bronze Reflecting glass and Ebony / coulissant vantail double, verre Bronze Reflecting et Ébène / Doppelflügel, bronzefarbenes Reflecting Glas und Ebenholz / de dos hojas, cristal Bronze Reflecting y Ébano

Particularité du mouvement "télescopique" des vantaux. A l'instar d'une antenne, les vantaux coulissent simultanément l'un dans l'autre dans le contre-châssis, dans une partie de la cloison mesurant la moitié de l'ouverture de passage. Une application particulière, fonctionnelle et d'un effet spectaculaire, grâce à la grande variété de combinaisons de matériaux proposée.

Besonderes Merkmal: „teleskopartige“ Bewegung der Türflügel. Wie eine Antenne lässt sich ein Teil des ersten Türflügels in den zweiten einschieben, woraufhin beide zusammen im Kastenrahmen verschwinden, der nur die Hälfte der Öffnungsweite einnimmt. Diese besondere Lösung ist nicht nur funktionell, sondern auch äußerst phantasievoll – dank der Varietät der kombinierbaren Materialien.

Se distingue por la peculiaridad del movimiento de las hojas de la puerta: "telescopico", exactamente como el de una antena, con una parte de la hoja de la puerta que se desliza dentro de la otra y, juntas, a su vez dentro del premarco, en una porción de pared de medida equivalente a la mitad de la luz de paso. Una aplicación muy singular, funcional y de gran impacto, con un espectacular efecto gracias a la variedad de los materiales combinables.



Unique Lorica anta doppia vetro Extra Clear, essenza Zebrano / double door, extra-clear glass and Zebrawood / coulissant vantail double, verre extra clear et Zèbrano / Doppelflügel, Extra-Clear-Glas und Zebrano / de dos hojas, cristal Extra Clear y Zebrano

DISPONIBILE NELLE VERSIONI:

SCORREVOLE INTERNO MURO, semplice e doppio con tre soluzioni di abbinamento per i pannelli: Legno più legno, Legno più Vetro, Vetro più Vetro.

**AVAILABLE
IN THE FOLLOWING VERSIONS:**

INTERNAL SLIDING DOOR SYSTEM, single and double with three possible panel combinations: Wood with Wood, Wood with Glass, Glass with Glass.



Unique Lorica anta doppia vetro bronze acidato / double door, etched bronze glass / coulissant vantail double, verre bronze acidé / Doppelflügel, bronzefarbenes Ätzglas / de dos hojas, cristal bronw translúcido

DISPONIBLE DANS LES VERSIONS:

COULISSANT À L'INTÉRIEUR DE LA CLOISON, simple et double avec trois solutions de combinaisons pour les vantaux: Bois plus Bois, Bois plus Verre, Verre plus Verre.

VERFÜGBAR IN DEN VERSIONEN:

SCHIEBETÜR AN WANDINNENSEITE, einfach und doppelt mit drei Kombinationsmöglichkeiten für die Türflügel: Holz + Holz, Holz + Glas, Glas + Glas.

DISPONIBLE EN LAS VERSIONES:

PUERTA CORREDERA EMPOTRADA EN LA PARED, de una y de dos hojas. Con tres tipos de combinación posibles en cuanto a las hojas: madera y madera, madera y cristal, cristal y cristal.

PARTICOLARI

MANIGLIA PER SCORREVOLE SENZA SERRATURA CROMO SATINATO



HANDLE FOR SLIDING DOOR, WITHOUT LOCK, SATIN CHROME

POIGNEE POUR VANTAIL COULISSANT SANS SERRURE CHROME SATINE

TÜRBECHLAG FÜR SCHIEBETÜR OHNE SCHLOSS, SATINIERTES CHROMFINISH

TIRADOR PARA CORREDERA SIN CERRADURA CROMO SATINADO

MANIGLIA PER SCORREVOLE CON SERRATURA CROMO SATINATO



HANDLE FOR SLIDING DOOR, WITH LOCK, SATIN CHROME

POIGNEE POUR VANTAIL COULISSANT AVEC SERRURE CHROME SATINE

TÜRBECHLAG FÜR SCHIEBETÜR MIT SCHLOSS, SATINIERTES CHROMFINISH

TIRADOR PARA CORREDERA CON CERRADURA CROMO SATINADO

MANIGLIA PER SCORREVOLE CON SERRATURA ORO SATINATO



HANDLE FOR SLIDING, WITH LOCK, SATIN BRASS

POIGNEE POUR VANTAIL COULISSANT AVEC SERRURE OR SATINE

TÜRBECHLAG FÜR SCHIEBETÜR MIT SCHLOSS, SATINIERTES GOLDFINISH

TIRADOR PARA CORREDERA CON CERRADURA ORO SATINADO

MANIGLIA PER SCORREVOLE SENZA SERRATURA ORO SATINATO



HANDLE FOR SLIDING DOOR, WITHOUT LOCK, SATIN BRASS

POIGNEE POUR VANTAIL COULISSANT SANS SERRURE OR SATINE

TÜRBSCHLAG FÜR SCHIEBETÜR OHNE SCHLOSS, SATINIERTES GOLDFINISH

TIRADOR PARA CORREDERA SIN CERRADURA ORO SATINADO

MANIGLIA PER BATTENTE CON SERRATURA CROMO SATINATO



HANDLE FOR SWINGING DOOR, WITH LOCK, SATIN CHROME

POIGNEE POUR BATTANT AVEC SERRURE CHROME SATINE

TÜRBSCHLAG FÜR DREHFLÜGELTÜR MIT SCHLOSS, SATINIERTES CHROMFINISH

TIRADOR PARA BATTIENTE CON CERRADURA CROMO SATINADO

MANIGLIA PER BATTENTE CON SERRATURA ORO SATINATO



HANDLE FOR SWINGING DOOR, WITH LOCK, SATIN BRASS

POIGNEE POUR BATTANT AVEC SERRURE OR SATINE

TÜRBSCHLAG FÜR DREHFLÜGELTÜR MIT SCHLOSS, SATINIERTES GOLD-FINISH

TIRADOR PARA BATTIENTE CON CERRADURA ORO SATINADO

MARCHIO SCRIGNO ORO SATINATO



SCRIGNO BRAND, SATIN BRASS

MARQUE SCRIGNO OR SATINÉ

MARKE SCRIGNO, SATINIERTES GOLDFINISH

MARCA SCRIGNO ORO SATINADO

MARCHIO SCRIGNO CROMO SATINATO



SCRIGNO BRAND, SATIN CHROME

MARQUE SCRIGNO CHROME SATINÉ

MARKE SCRIGNO, SATINIERTES CHROMFINISH

MARCA SCRIGNO CROMO SATINADO

BORDO PROFILO SU ANTA FLYER



PROFILE EDGE ON FLYER DOOR

BORD PROFIL SUR VANTAIL FLYER

PROFILKANTE AN TÜRFLÜGEL FLYER

BORDE PERFIL EN HOJA FLYER

CERNIERA ANTA FLYER BATTENTE



FLYER SWINGING DOOR HINGE

CHARNIÈRE VANTAIL FLYER BATTANT

DREHFLÜGEL-TÜRSCHARNIER FLYER

BISAGRA HOJA FLYER BATTENTE

DISEGNI TECNICI E TABELLE

UNIQUE FLYER E MIND SCORREVOLE A SCOMPARSA anta singola

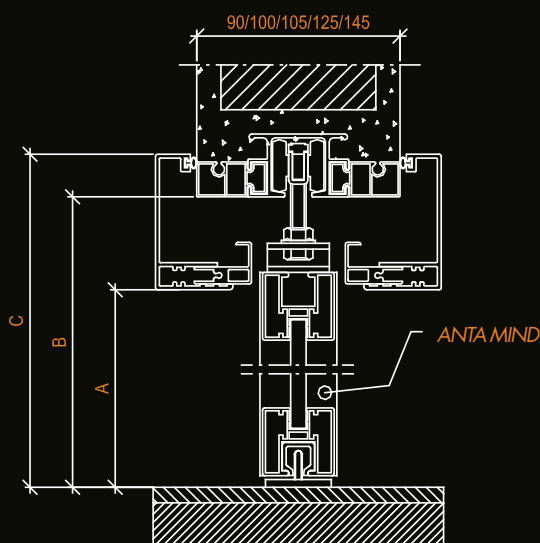
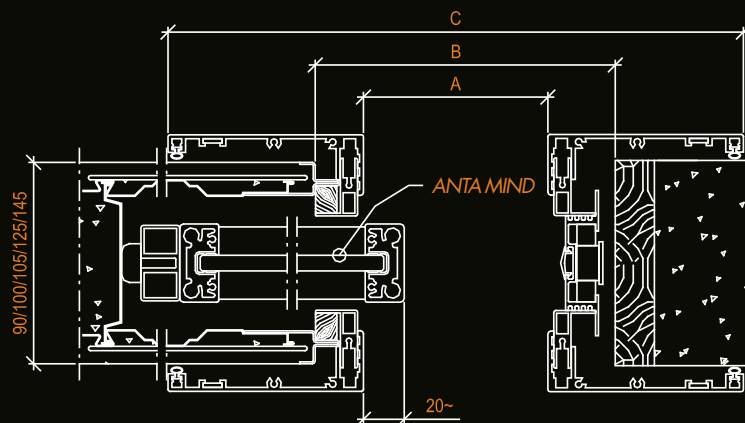

ANTA SINGOLA / SINGLE DOOR

A	B	C
Luce di passaggio / Opening measurements	Luce falso telaio / Sub frame opening	Ingombro stipite / Door post dimensions
Larghezza x altezza Width by height	Larghezza x altezza Width by height	Larghezza x altezza Width by height
600 x 2100	655 x 2150	795 x 2170
700 x 2100	755 x 2150	895 x 2170
750 x 2100	805 x 2150	995 x 2170
800 x 2100	855 x 2150	1095 x 2170
900 x 2100	955 x 2150	1195 x 2170
1000 x 2100	1055 x 2150	1295 x 2170
1100 x 2100	1155 x 2150	1395 x 2170
1200 x 2100	1255 x 2150	1495 x 2170

UNIQUE FLYER E MIND SCORREVOLE A SCOMPARSA anta doppia

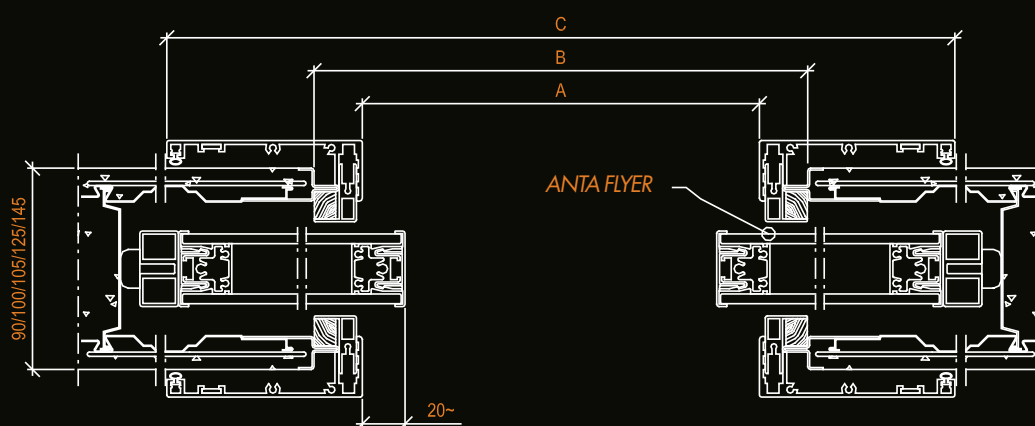

ANTA DOPPIA / DOUBLE DOOR

A Luce di passaggio / Opening measurements	B Luce falso telaio / Sub frame opening	C Ingombro stipite / Door post dimensions
Larghezza x altezza Width by height	Larghezza x altezza Width by height	Larghezza x altezza Width by height
1200 x 2100	1255 x 2150	1400 x 2170
1400 x 2100	1455 x 2150	1600 x 2170
1600 x 2100	1655 x 2150	1800 x 2170
1800 x 2100	1855 x 2150	2000 x 2170
2000 x 2100	2055 x 2150	2200 x 2170
2200 x 2100	2255 x 2150	2400 x 2170
2400 x 2100	2455 x 2150	2600 x 2170

UNIQUE FLYER E MIND SCORREVOLE A SCOMPARSA PER ESSENTIAL anta singola

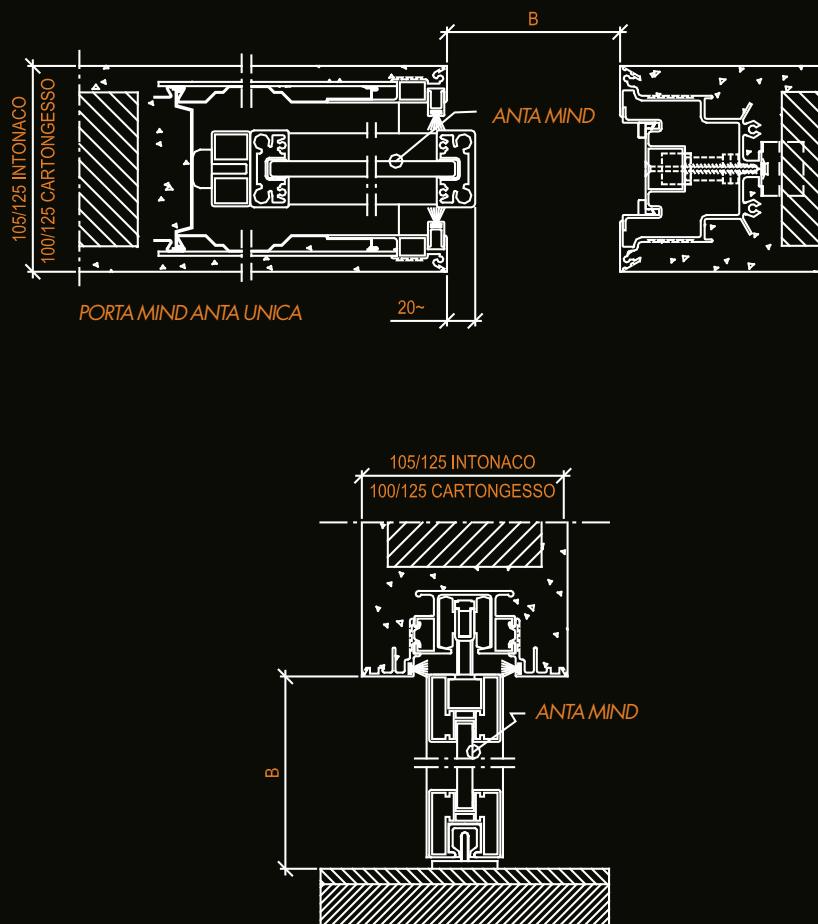

ANTA SINGOLA / SINGLE DOOR	
A Luce di passaggio nominale <i>Net opening measurements</i>	B Luce di passaggio effettiva <i>Clear opening size</i>
Larghezza x altezza <i>Width by height</i>	Larghezza x altezza <i>Width by height</i>
600 x 2000	590 x 1910 ÷ 2000
600 x 2100	590 x 2010 ÷ 2100
700 x 2000	690 x 1910 ÷ 2000
700 x 2100	690 x 2010 ÷ 2100
750 x 2000	740 x 1910 ÷ 2000
750 x 2100	740 x 2010 ÷ 2100
800 x 2000	790 x 1910 ÷ 2000
800 x 2100	790 x 2010 ÷ 2100
900 x 2000	890 x 1910 ÷ 2000
900 x 2100	890 x 2010 ÷ 2100
1000 x 2000	990 x 1910 ÷ 2000
1000 x 2100	990 x 2010 ÷ 2100
1100 x 2000	1090 x 1910 ÷ 2000
1100 x 2100	1090 x 2010 ÷ 2100
1200 x 2000	1190 x 1910 ÷ 2000
1200 x 2100	1190 x 2010 ÷ 2100

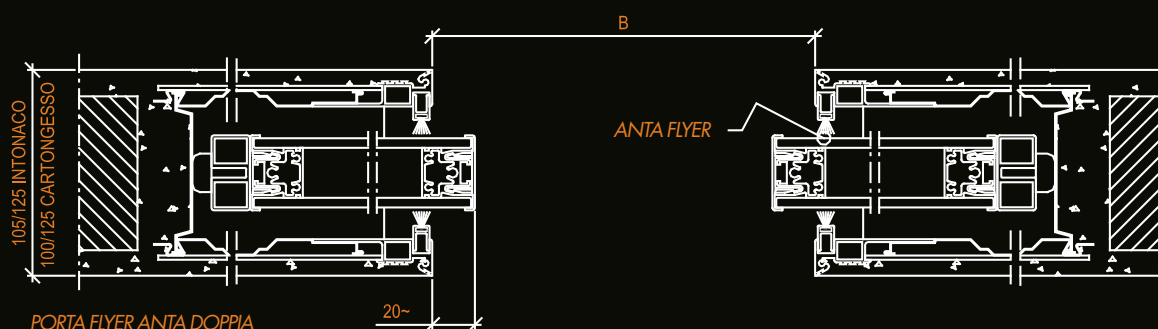

ANTA DOPPIA / DOUBLE DOOR	
A Luce di passaggio nominale <i>Net opening measurements</i>	B Luce di passaggio effettiva <i>Clear opening size</i>
Larghezza x altezza <i>Width by height</i>	Larghezza x altezza <i>Width by height</i>
1200 x 2000	1200 x 1910 ÷ 2000
1200 x 2100	1200 x 2010 ÷ 2100
1400 x 2000	1400 x 1910 ÷ 2000
1400 x 2100	1400 x 2010 ÷ 2100
1600 x 2000	1600 x 1910 ÷ 2000
1600 x 2100	1600 x 2010 ÷ 2100
1800 x 2000	1800 x 1910 ÷ 2000
1800 x 2100	1800 x 2010 ÷ 2100
2000 x 2000	2000 x 1910 ÷ 2000
2000 x 2100	2000 x 2010 ÷ 2100
2200 x 2000	2200 x 1910 ÷ 2000
2200 x 2100	2200 x 2010 ÷ 2100
2400 x 2000	2400 x 1910 ÷ 2000
2400 x 2100	2400 x 2010 ÷ 2100

UNIQUE FLYER E MIND SCORREVOLE ESTERNA MURO CON STIPITE anta singola

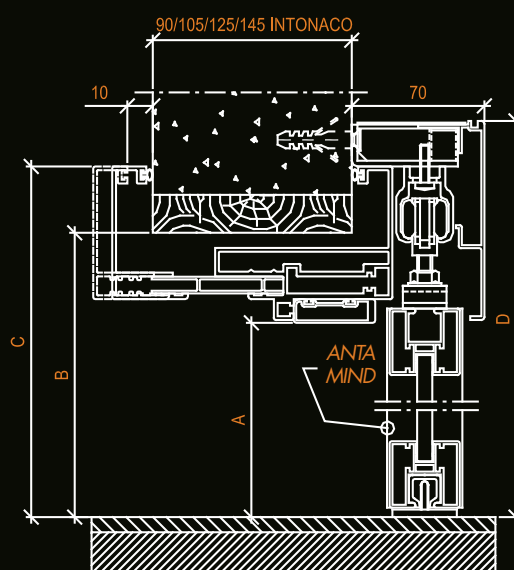
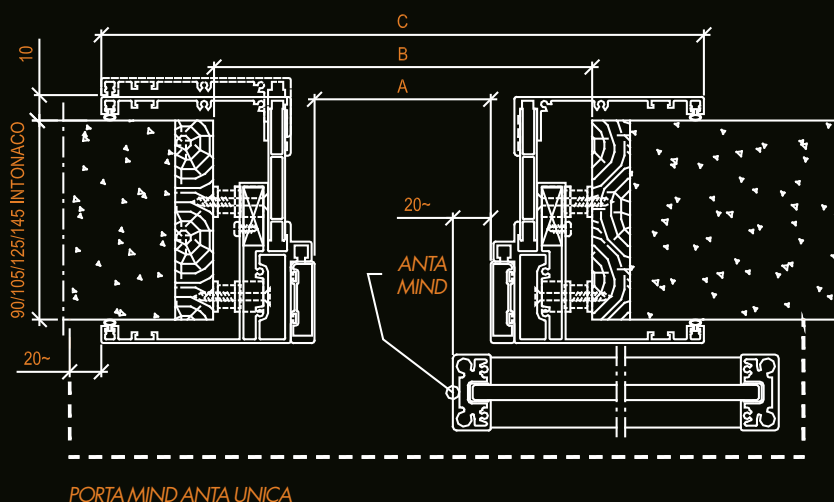

ANTA SINGOLA / SINGLE DOOR

A Luce di passaggio / Opening measurements	B Luce falso telaio / Sub frame opening	C Ingombro stipite / Door post dimensions	D Ingombro mantovana / Timber head dimensions
Larghezza x altezza Width by height	Larghezza x altezza Width by height	Larghezza x altezza Width by height	Larghezza x altezza Width by height
600 x 2100	685 ÷ 700 x 2140 ÷ 2150	795 x 2185	1340 x 2210
700 x 2100	785 ÷ 800 x 2140 ÷ 2150	895 x 2185	1540 x 2210
800 x 2100	885 ÷ 900 x 2140 ÷ 2150	995 x 2185	1740 x 2210
900 x 2100	985 ÷ 1000 x 2140 ÷ 2150	1095 x 2185	1940 x 2210
1000 x 2100	1085 ÷ 1100 x 2140 ÷ 2150	1195 x 2185	2140 x 2210

UNIQUE FLYER E MIND SCORREVOLE ESTERNA MURO CON STIPITE anta doppia

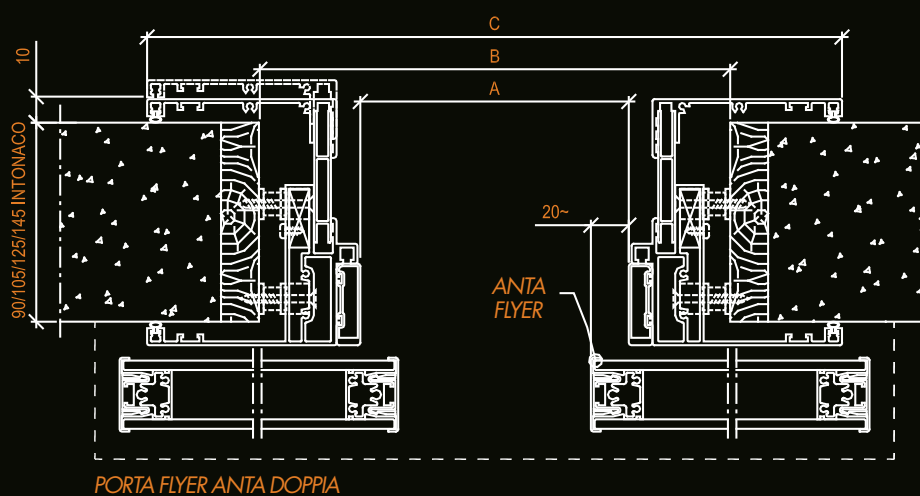

ANTA DOPPIA / DOUBLE DOOR

A Luce di passaggio / Opening measurements	B Luce falso telaio / Sub frame opening	C Ingombro stipite / Door post dimensions	D Ingombro mantovana / Timber head dimensions
Larghezza x altezza Width by height	Larghezza x altezza Width by height	Larghezza x altezza Width by height	Larghezza x altezza Width by height
1200 x 2100	1285 ÷ 1300 x 2140 ÷ 2150	1395 x 2185	2435 x 2210
1400 x 2100	1485 ÷ 1500 x 2140 ÷ 2150	1595 x 2185	2835 x 2210
1600 x 2100	1685 ÷ 1700 x 2140 ÷ 2150	1795 x 2185	3235 x 2210
1800 x 2100	1885 ÷ 1900 x 2140 ÷ 2150	1995 x 2185	3635 x 2210
2000 x 2100	2085 ÷ 2100 x 2140 ÷ 2150	2195 x 2185	4035 x 2210

UNIQUE FLYER E MIND SCORREVOLE ESTERNA MURO SENZA STIPITE anta singola

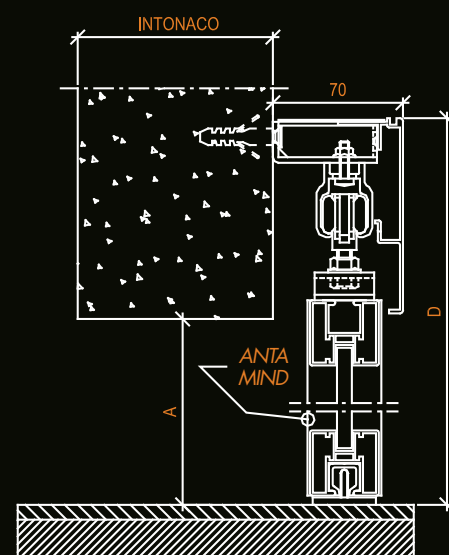
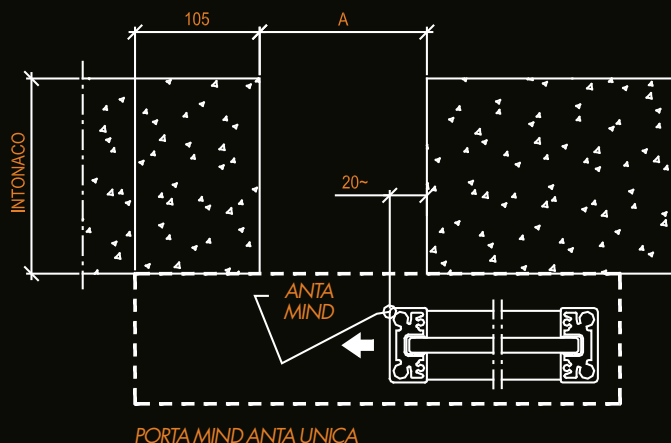

ANTA SINGOLA / SINGLE DOOR	
A Luce di passaggio <i>Opening measurements</i>	D Ingombro mantovana <i>Timber head dimensions</i>
Larghezza x altezza <i>Width by height</i>	Larghezza x altezza <i>Width by height</i>
590 x 2100	1340 x 2210
690 x 2100	1540 x 2210
790 x 2100	1740 x 2210
890 x 2100	1940 x 2210
990 x 2100	2140 x 2210

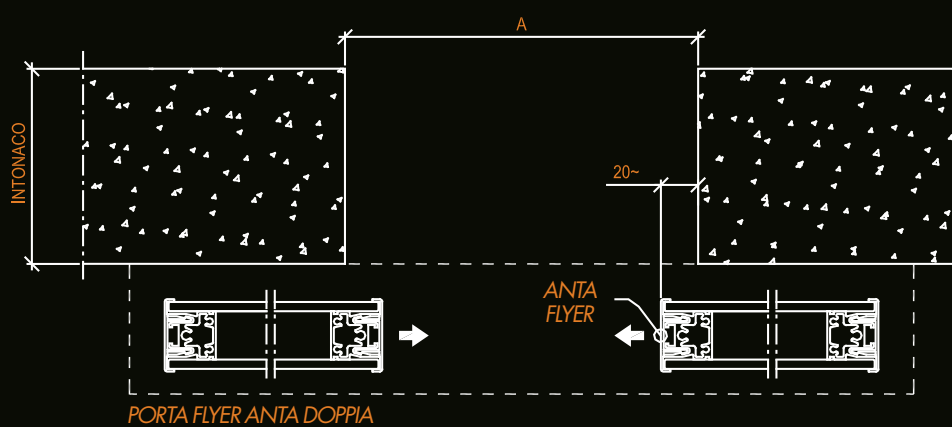

ANTA DOPPIA / DOUBLE DOOR	
A Luce di passaggio Opening measurements	D Ingombro mantovana Timber head dimensions
Larghezza x altezza Width by height	Larghezza x altezza Width by height
1190 x 2000	2435 x 2210
1390 x 2100	2835 x 2210
1590 x 2000	3235 x 2210
1790 x 2100	3635 x 2210
1990 x 2000	4035 x 2210

UNIQUE FLYER BATTENTE anta singola

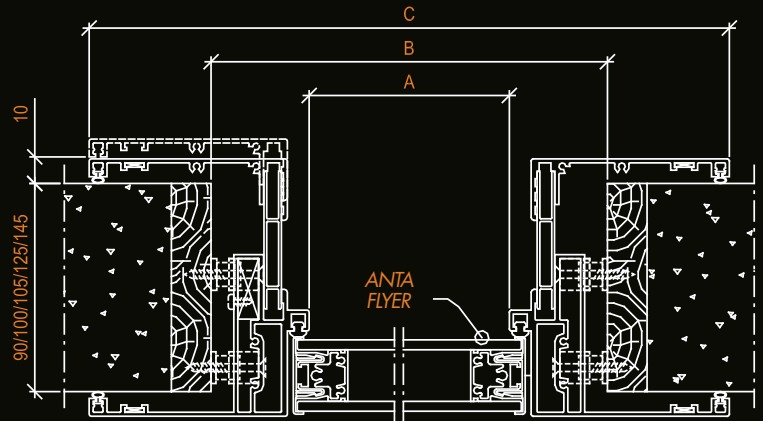
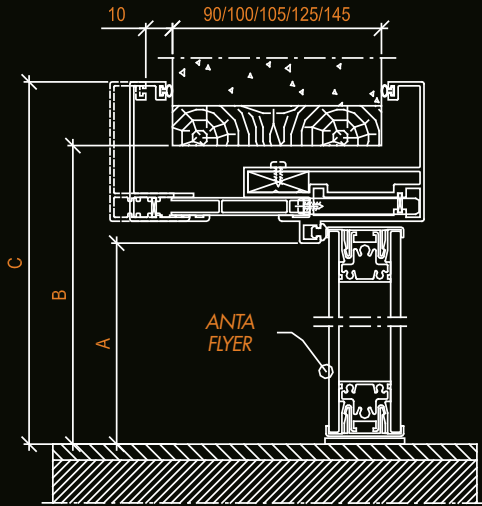

PORTA FLYER ANTA BATTENTE

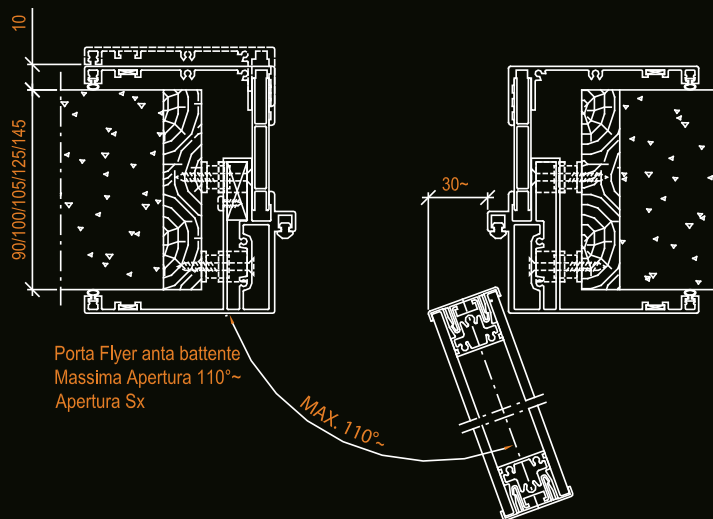

Porta Flyer anta battente
Massima Apertura 110°~
Apertura Sx

ANTA SINGOLA / SINGLE DOOR

A	B	C
Luce di passaggio / Opening measurements	Luce falso telaio / Sub frame opening	Ingombro stipite / Door post dimensions
Larghezza x altezza Width by height	Larghezza x altezza Width by height	Larghezza x altezza Width by height
700 x 2100	790 ÷ 800 x 2140 ÷ 2150	925 x 2183
800 x 2100	890 ÷ 900 x 2140 ÷ 2150	1025 x 2183
900 x 2100	990 ÷ 1000 x 2140 ÷ 2150	1125 x 2183

UNIQUE FLYER ESSENTIAL BATTENTE anta singola

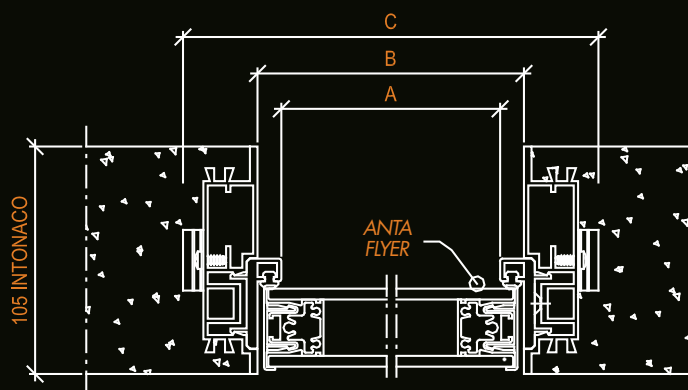
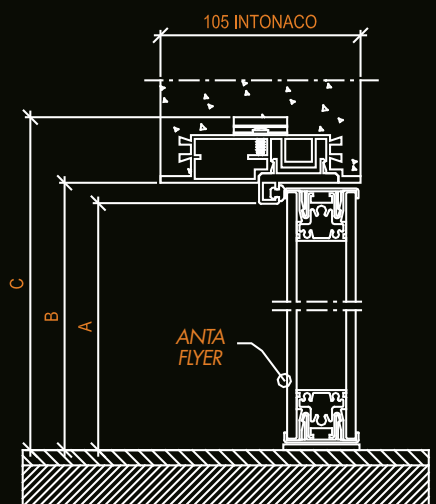

PORTA FLYER ANTA BATTENTE

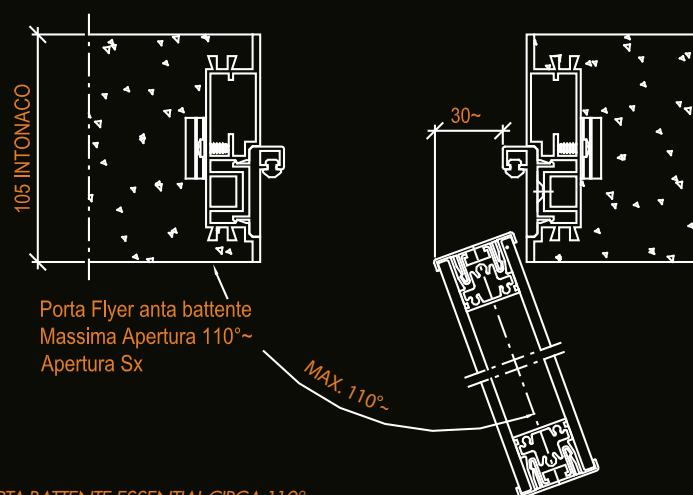

Porta Flyer anta battente
Massima Apertura 110°~
Apertura Sx

MASSIMA APERTURA PER PORTA BATTENTE ESSENTIAL CIRCA 110°

ANTA SINGOLA / SINGLE DOOR

A	B	C
Luce di passaggio / Opening measurements	Luce falso telaio / Sub frame opening	Ingombro stipite / Door post dimensions
Larghezza x altezza Width by height	Larghezza x altezza Width by height	Larghezza x altezza Width by height
700 x 2100	722 x 2111	800 x 2150
800 x 2100	822 x 2111	900 x 2150
900 x 2100	922 x 2111	1000 x 2150

UNIQUE MIND BATTENTE anta singola

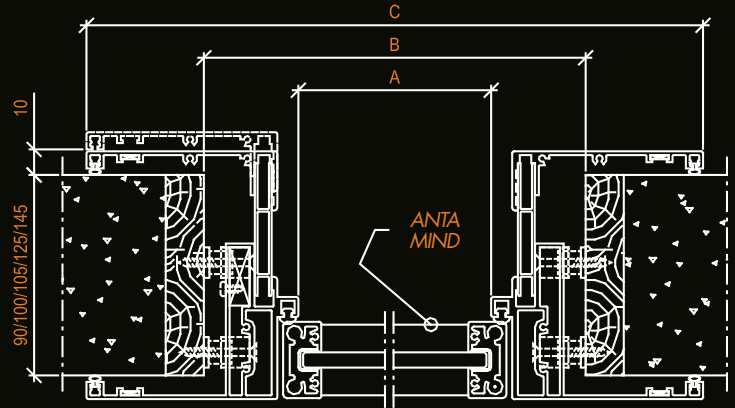
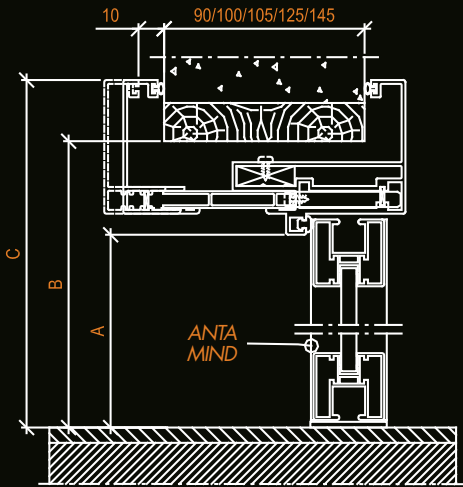

PORTA MIND ANTA BATTENTE

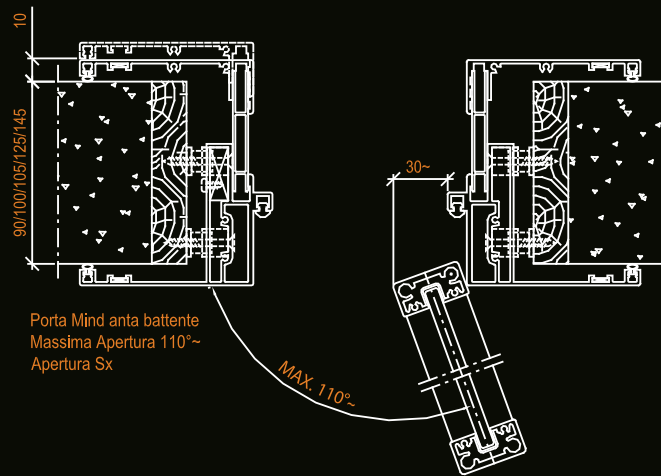

ANTA SINGOLA / SINGLE DOOR

A	B	C
Luce di passaggio / Opening measurements	Luce falso telaio / Sub frame opening	Ingombro stipite / Door post dimensions
Larghezza x altezza Width by height	Larghezza x altezza Width by height	Larghezza x altezza Width by height
700 x 2100	790 ÷ 800 x 2140 ÷ 2150	925 x 2183
800 x 2100	890 ÷ 900 x 2140 ÷ 2150	1025 x 2183
900 x 2100	990 ÷ 1000 x 2140 ÷ 2150	1125 x 2183

UNIQUE MIND ESSENTIAL BATTENTE anta singola

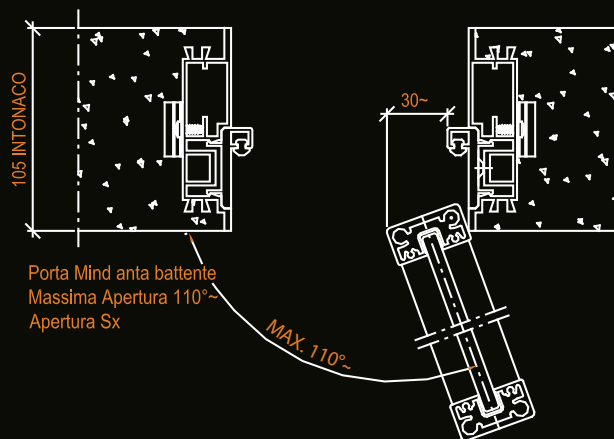
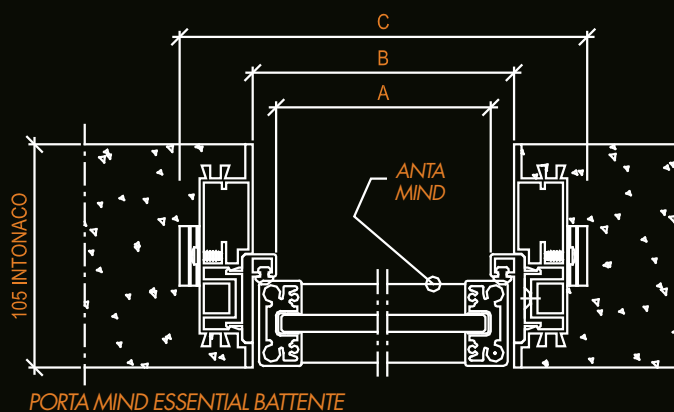
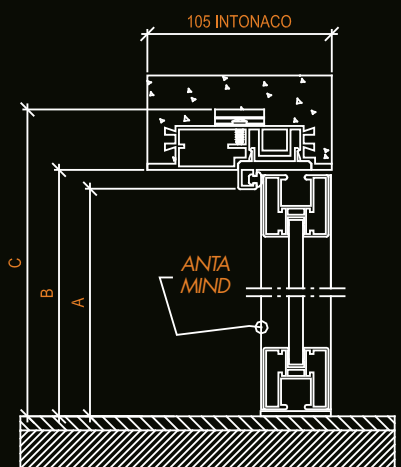

ANTA SINGOLA / SINGLE DOOR

A	B	C
Luce di passaggio / Opening measurements	Luce falso telaio / Sub frame opening	Ingombro stipite / Door post dimensions
Larghezza x altezza Width by height	Larghezza x altezza Width by height	Larghezza x altezza Width by height
700 x 2100	722 x 2111	800 x 2150
800 x 2100	822 x 2111	900 x 2150
900 x 2100	922 x 2111	1000 x 2150

UNIQUE LORICA SCORREVOLE TELESCOPICO A SCOMPARSA anta singola

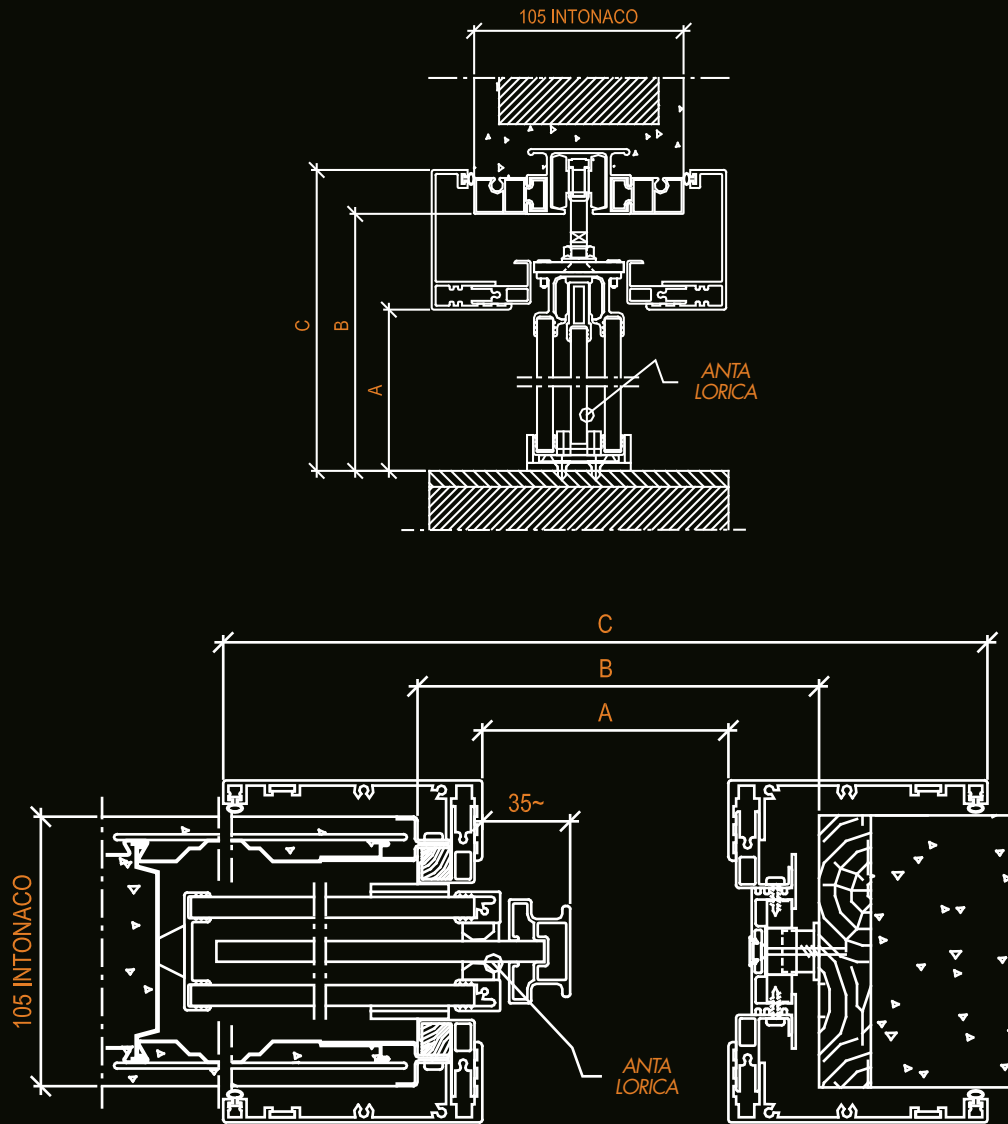

PORTA LORICA ANTA SINGOLA

ANTA SINGOLA / SINGLE DOOR		
A Luce di passaggio / Opening measurements	B Luce falso telaio / Sub frame opening	C Ingombro stipite / Door post dimensions
Larghezza x altezza Width by height	Larghezza x altezza Width by height	Larghezza x altezza Width by height
600 x 2100	655 x 2150	795 x 2170
800 x 2100	855 x 2150	995 x 2170
1000 x 2100	1055 x 2150	1195 x 2170
1200 x 2100	1255 x 2150	1395 x 2170

Le fotografie, i disegni, le illustrazioni, le essenze ed i colori hanno valore puramente indicativo. Tutti i modelli possono subire in qualsiasi momento, senza preavviso, qualche lieve variazione nelle sezioni, nella struttura e nel disegno; pertanto, qualora a nostro insindacabile giudizio, resti immutata l'estetica complessiva e la solidità della porta, il Cliente non potrà recedere dal contratto, né avrà diritto a sconti o abbuoni particolari. The photographs, drawings, illustrations, types of wood and colours have a purely indicative value. All models may be subject to slight variations at any time, without prior notice, in the sections, structure and design; therefore, should the manufacturer retain that the overall aesthetics and solidity of the door are unchanged, the Customer may not withdraw from the contract, nor have the right to special discounts or allowances.

UNIQUE LORICA SCORREVOLE TELESCOPICO A SCOMPARSA anta doppia

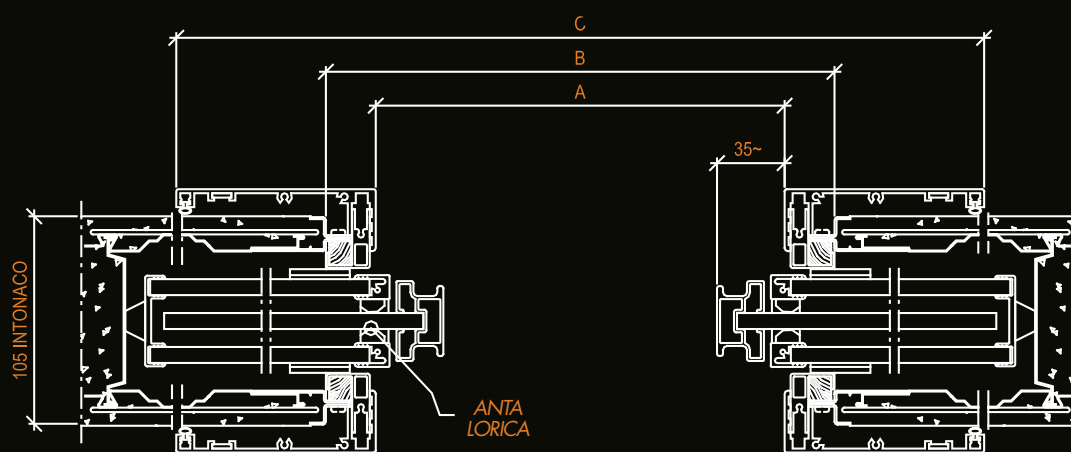

PORTA LORICA ANTA DOPPIA

ANTA DOPPIA / DOUBLE DOOR

A Luce di passaggio / Opening measurements	B Luce falso telaio / Sub frame opening	C Ingombro stipite / Door post dimensions
Larghezza x altezza Width by height	Larghezza x altezza Width by height	Larghezza x altezza Width by height
1200 x 2100	1255 x 2150	1400 x 2170
1600 x 2100	1655 x 2150	1800 x 2170
2000 x 2100	2055 x 2150	2200 x 2170
2400 x 2100	2455 x 2150	2600 x 2170

E
U
Q
I
Z

Unique
by SCRIGNO

SCRIGNO SpA
via Casale 975 - 47822 S. Ermete di Santarcangelo (RN) - ITALY
Tel. +39 0541 757711 - Fax +39 0541 757780
e-mail: scrigno@scrigno.it - www.scrigno.net

U